

**CHIKOUSA**

CK- | STEEL SOLAR CARPORT | GAZEBO



**1-CAR PREMIER  
STEEL SOLAR CARPORT | GAZEBO  
INSTALLATION MANUAL**

VERSION: 03.30.26 VO2 | ENG

**WARNING****Photovoltaic Hazard Control &  
Structural Building Safety****(To Reduce Risk of Injury-Read and Follow All Instructions)**

---

The installation of solar electric panels should only be performed by trained and qualified personnel. Unauthorized persons and children should not be allowed near the solar electric installation. Follow all permit, installation, and inspection requirements to include all applicable local, regional, and national electrical codes. Follow the safety precautions of all other system components.

Structural installation shall comply with all relevant local government standards, manufacturer's instructions and specification and safe building practices.

Follow the risk management process prior to commencing work- including identifying all potential hazards and assessed risks while eliminating or mitigating them from the jobsite.

Consult with all approved competent parties who will be involved in working on the jobsite. Develop safe working procedures for installing the structure and the solar panels using information obtained during the risk management process.

Wear all required Personal Protective Equipment during every phase of construction.

Always use equipment/tools/machinery safely and properly. Components are designed for "single use only", i.e. not for multiple construct and deconstruct projects.

Maintenance can only be performed by qualified personnel

- Any loose components or fasteners shall be re-tightened in accordance with these instructions
- Any components showing signs of damage shall be replaced immediately

Always use the most recent version of the installation manual before installing your Carport/Gazebo. The installation Manual is subject to change without notice. Please consult with CHIKOUSA to ensure you are utilizing the latest Install Manual.

## BRIEF DESCRIPTION

The CK-Steel Carport/Gazebo is a robust solar carport that can accommodate a wide range of panel sizes, with a max (North/South or Up/Down) span of 270". This structure can be installed with a 2-3 person crew, without the need of any heavy duty tools. The Installation should always be completed by trained professional and/or qualified individuals, who have been adequately instructed and trained about the tasks involved with the installation, including the usage of protective devices, protective measures, relevant provisions, safety regulations and local operating site conditions and have proven competence in all areas of the installation.

Please read carefully this installation manual and all other applicable documents before starting your installation. Please contact CHIKO with any questions that you may have.

## MAINTENANCE

1. When signs of rust appear, or when the paint is peeled or removed, you must take steps to remove the rust and paint the affected areas.
2. You must check the bolts once a year ensuring all connections are secure, and after any major storm or weather occurrence. Tighten all bolts according to torque specs.
3. If the columns of the structure are hit, you must replace the columns of the structure immediately.

## WARNING

If any structural component of the system to include the column, beam, base plate, or rail are damaged they must be replaced immediately.

## FOOTER WARNING

Anyone who plans to dig should call 811 or visit their state's 811 center's website a few business days before digging to request that the approximate location of buried utilities be marked with paint or flags so that you don't unintentionally dig into an underground utility line.

## MEASUREMENT NOTE

All measurements have been converted from MM to Inches. The accuracy of measurement can vary slightly from mm to inches. All measurements are available in MM for detailed accuracy. The most critical measurement required is the Base Plate placement location. Please review the Construction Drawings for the Base Plate and Base Plate locations prior to installation.

## REQUIRED INSTALLATION TOOLS

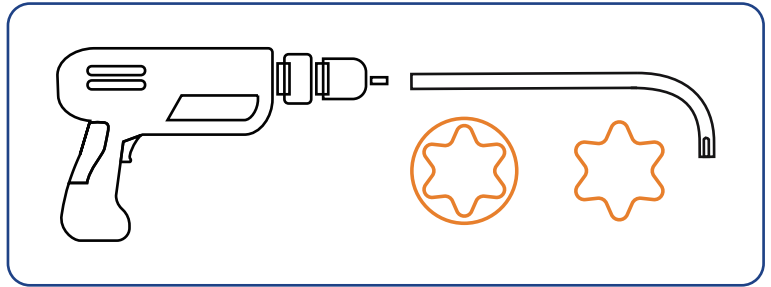
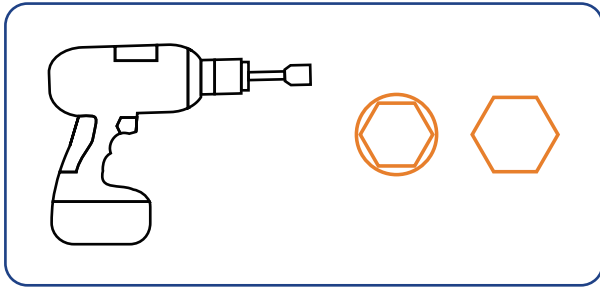

WRENCH



GLOVES



CHALK LINE

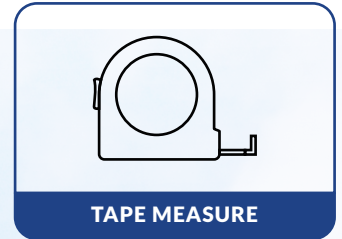

TAPE MEASURE



RUBBER MALLET



HARDHAT



SAFETY GLASSES



HEARING PROTECTION



FOOT PROTECTION

## MAIN COMPONENTS



142 $\frac{1}{8}$ "

M RAIL

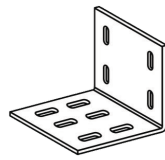

C-CHANNEL FIX KIT

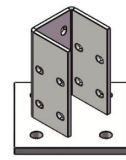

BASE PLATE

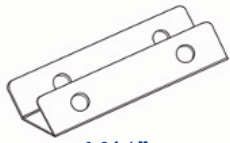

16 $\frac{1}{2}$ "

LOWER BEAM &  
DIAGONAL BRACE ADAPTER

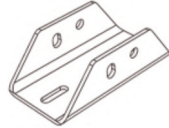

10 $\frac{3}{16}$ "

TOP COLUMN ADAPTER

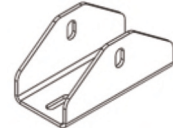

10 $\frac{3}{16}$ "

DIAGONAL BRACE ADAPTER

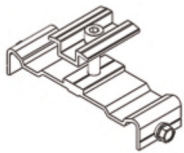

MID-CLAMP

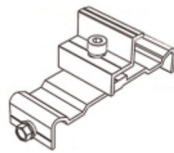

END-CLAMP



WATER CHANNEL



RUBBER STRIPPING

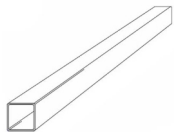

111"

FRONT COLUMN

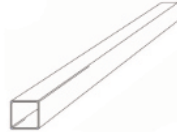

126 $\frac{1}{2}$ "

REAR COLUMN



168 $\frac{1}{2}$ "

LOWER HORIZONTAL BEAM



224 $\frac{7}{16}$ "

L-ANGLE SUPPORT



228 $\frac{5}{16}$ "

SUPPORT BEAM



47 $\frac{1}{4}$ "

DIAGONAL BRACE



149 $\frac{5}{8}$ "

C-CHANNEL

### NOTE

Customer needs to source materials for footings based on structural engineer specifications.

## MAIN COMPONENTS

### Overview

The following is a diagram that lists the main components of the CK- Carport System.

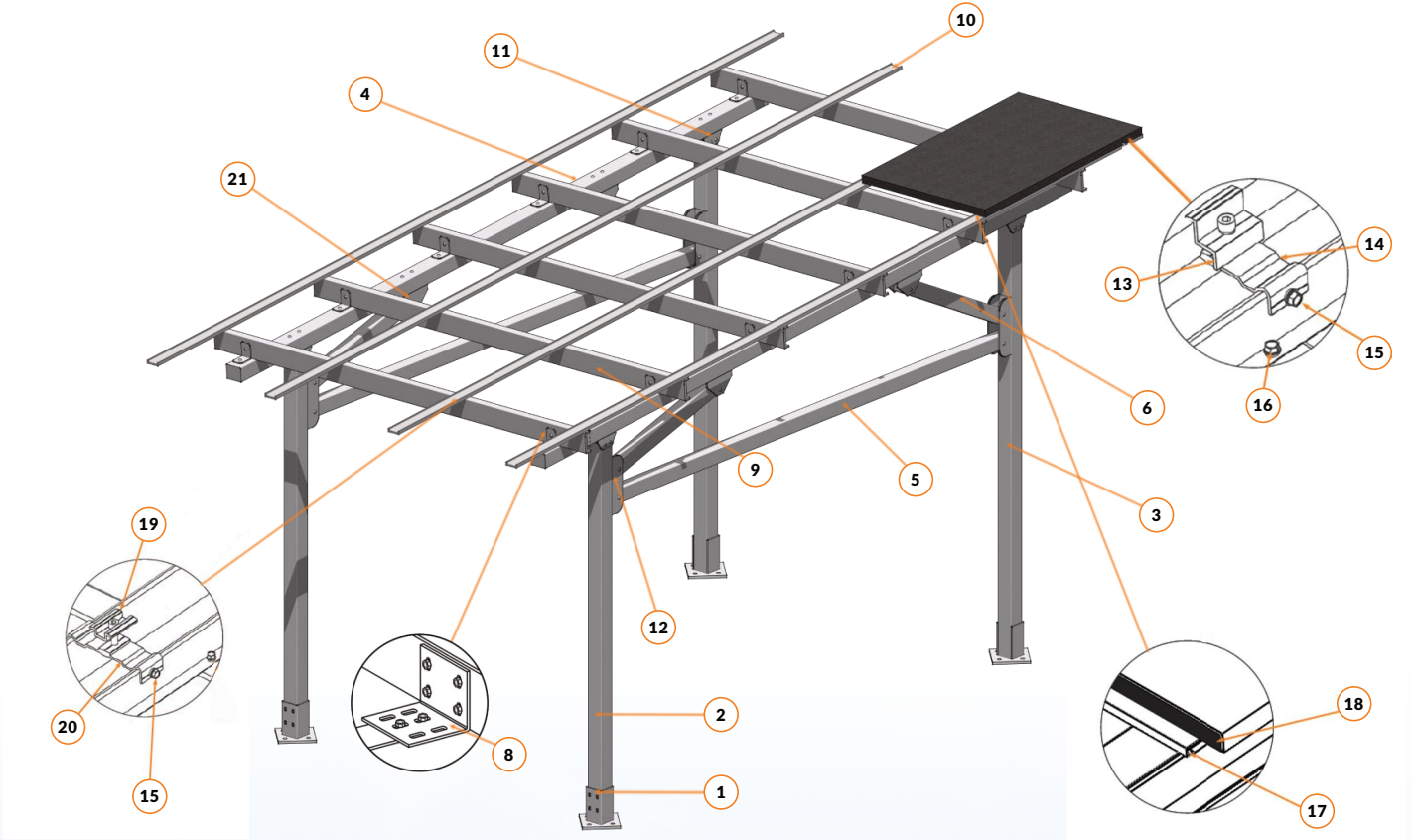

No	Description	QTY
1	Base Plate	4
2	Front Column 111"	2
3	Rear Column 126½"	2
4	Support Beam 228 <sup>5</sup> / <sub>16</sub> "	2
5	Lower Horizontal Beam 168 <sup>1</sup> / <sub>16</sub> "	2
6	Diagonal Brace 47 <sup>1</sup> / <sub>4</sub> "	4
7	L-Angle Support 224 <sup>7</sup> / <sub>16</sub> " (not shown)	1
8	C-Channel Fix Kit	12
9	C-Channel 149 <sup>5</sup> / <sub>8</sub> "	6
10	M-Rail 142 <sup>3</sup> / <sub>8</sub> "	8
11	Top Column Adapter 10 <sup>3</sup> / <sub>16</sub> "	4
12	Low Beam & Diagonal Brace Adapter 16 <sup>1</sup> / <sub>2</sub> "	4

No	Description	QTY
13	End Clamp 30, 35, & 40MM	16
14	End Clamp Share Plate	16
15	6.3*16 hex flange self-drilling screw	160
16	6.3*25 hex flange self-drilling screw	48
17	Water Channel	9
18	Rubber Stripping (1 Roll)	
19	Mid Clamp	16
20	Mid Clamp Share Plate	16
21	Diagonal Brace Adapter 10 <sup>3</sup> / <sub>16</sub> "	4
22	M10*35 Bolt Kit (not shown)	48
23	M16*180 Bolt Kit (not shown)	104



**FRONT VIEW**



**SIDE VIEW**

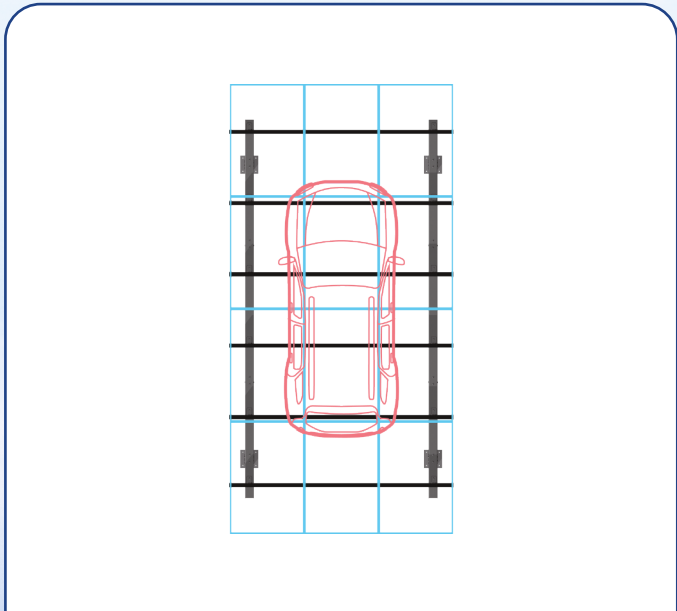

**OVERHEAD VIEW**



**LARGE FORMAT MODULE VIEW**

## COMPONENTS LIST

CAT	Picture	Description Part	Details	QTY
1		Carport Support Structure	Front Columns	2
			Rear Columns	2
		CK-ZEM-CP3-5	Base Plate	4
		<u>COLUMNS</u>	Support Beam	2
		CK-001-016-014	Top Column Adapter	4
		<u>BEAMS</u>	Lower Horizontal Beam	2
		GT-001-016-014	Diagonal Brace	4
		Base 'Plate'	Low Beam & Diagonal Brace Adapter	4
		CK-GT-001-016-805	HDG Bolt M10*35	48
		GT-001-016-805	HDG Bolt M16*180	104
		Column/Beam Adapters	HDG Nut M10	48
			HDG Nut M16	104
		Beam	HDG Washer M10	48
		CK-GT-001-016-014	HDG Washer M16	208
		Column	HDG Spring Washer M10	96
CK-001-016-014	HDG Spring Washer M16	104		
2		M Rail CK-ZEM-010-5760	M Water-proof Rail	8
			Self Tapping Screw	30
3		Water Channel CK-009-1062	Water Channel	9
4		Rubber Stripping CK-IP-160-1133	Rubber Stripping	
5		C Channel CK-PL-C140-001-016-6000	C-Channel 149 <sup>5</sup> / <sub>8</sub> "	6
6		L Angle Support	224 <sup>3</sup> / <sub>8</sub> "	1

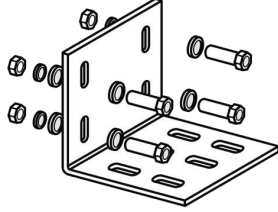
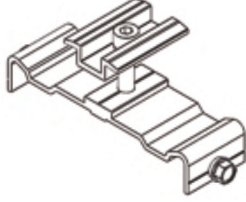
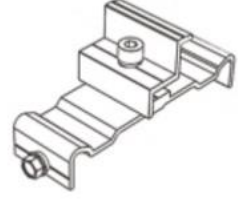
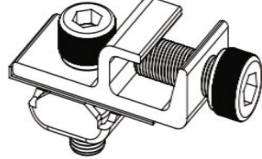
CAT	Picture	Description Part	Details	QTY
7		C-Channel Fix Kit CK-PL-GT001-016-14	C-Channel Fix Kit	12
			HDG Bolt M10*35	48
			HDG Bolt M16*180	24
			HDG Nut M10	48
			HDG Nut M16	24
			HDG Washer M10	96
			HDG Washer M16	48
			HDG Spring Washer M10	48
			HDG Spring Washer M16	24
8		Mid Clamp CK-782-4-60-Q  BRACKET # #CK-A845-801	35mm Mid Clamp	16
			845 Share Plate	16
			M Grounding Plate	16
			Self Tapping Screw	64
			SS304 Bolt M8*45	16
			SS304 Spring Washer M8	16
9		End Clamp CK-737-3-60-Q  BRACKET # #CK-1845-801	35mm End Clamp	16
			845 Share Plate	16
			M Grounding Plate	16
			Self Tapping Screw	24
			SS304 Bolt M8*45	12
			SS304 Spring Washer M8	12
10		Grounding Lug CK-GTC-R2	Grounding lug - weeb lug 8.0	6
			SS304 outer hex bolt 1/4" *0.6"	6
			SS304 inner hex bolt M8*20	6
			SS304 inner hex bolt M8*20	6

## INSTALLATION STEPS

### 1. Build Base

#### Solution A, Build base

- ✓ Mark footer location according to the diagram. Verify all angles are square (See Attached Planset).
- ✓ Dig footers and make base with anchor bolts according to site conditions and system specifications and based on your structural engineer instructions for foundations requirements.
- ✓ If the ground is unlevel, ensure that all footer placements are level and at the same height regardless of the terrain elevation. Never install the structure tilted, the columns must always be straight.
- ✓ The structure's foundations should be calculated taking into account site conditions, soil type, seismic conditions, maximum wind and snow loads for the site location and the product mechanical loading specifications. In some cases, a geotechnical study is required. Please consult with your local structural engineer.
- ✓ In areas subject to freezing, footer depths may have to increase to resist freeze heave. Always consult a structural engineer to confirm footer depth and dimension.

#### Solution B, Concrete anchors

- ✓ Concrete anchors can be utilized if approved by a structural engineer.

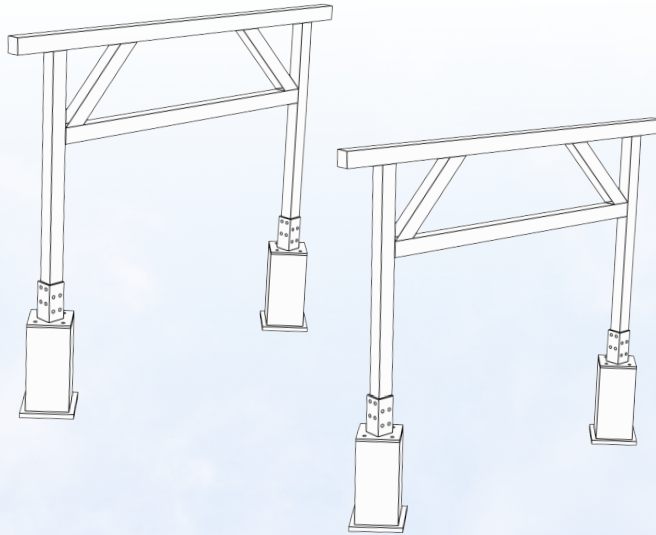

#### Solution C, Monster Mount

- ✓ Please follow Monster Mount Installation Guidelines.

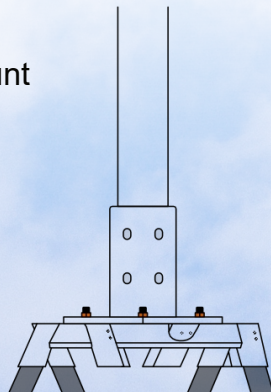

## 2. Install Base Plates

- ✓ Slide the column base plate over the concrete anchors and secure them. If you are using leveling nuts to level the column base plate. Correct any shifting if needed and repeat for the other three column base plates. Fill the gap between the base plate and the footing with Dry-pack non-shrink grout.
- ✓ Verify the distance between the front and rear column conform with the attached planset.

### Over Monster Mount

Follow Monster Mount Installation Guide.

Products Name	Quantity
Base	4

### Over Concrete Anchors

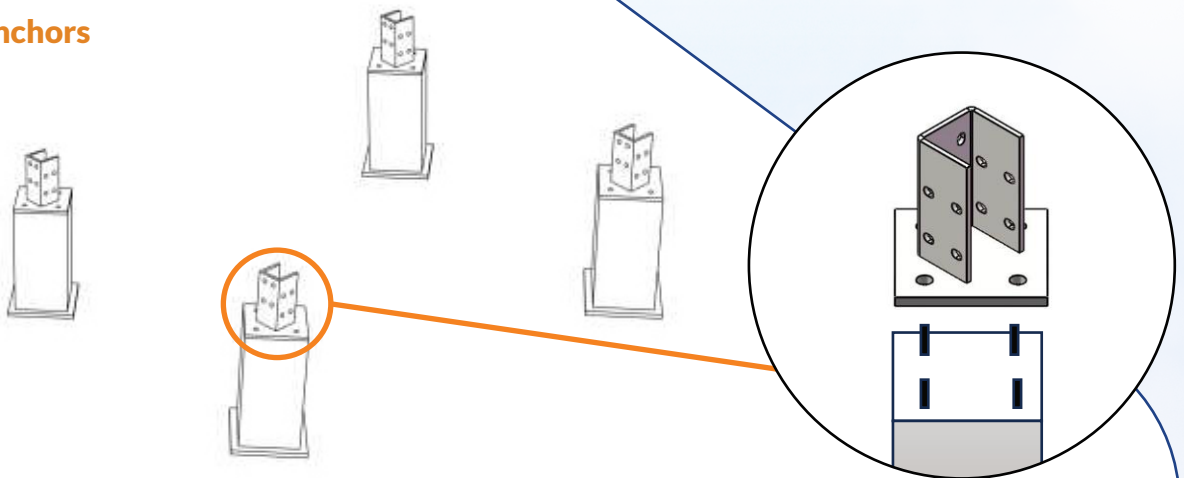

### Over Monster Mount

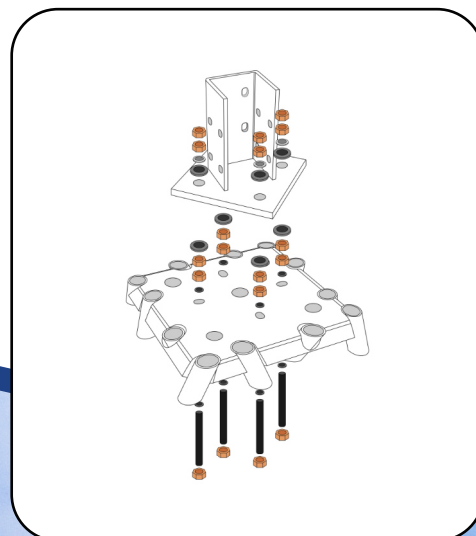

## 3. Fix Adapter

- ✓ A. Fix Low Beam/Diagonal Brace Adapter to Front & Rear Columns
- ✓ B1. Attach C-Channel Fix Kit to Support Beam
- ✓ B2. Attach Top Column Adapter to Support Beam

Front Column: 111"  
 Rear Column: 126 $\frac{1}{2}$ "  
 Low Beam/Diagonal Brace Adapter: 16 $\frac{1}{2}$ "  
 Top Column Adapter: 10 $\frac{3}{16}$ "  
 Support Beams: 228 $\frac{5}{16}$ "

Products Name	Quantity
Top Column Adapter	4
M16*180mm Bolt Kits (1 big flat washer + 1spring washer + 1 nut)	32
Low Beam/Diagonal Brace Adapter	4
C-Channel Fix Kit	12

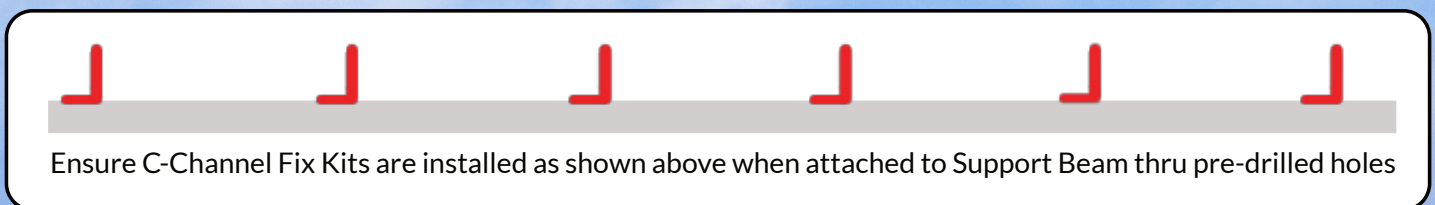
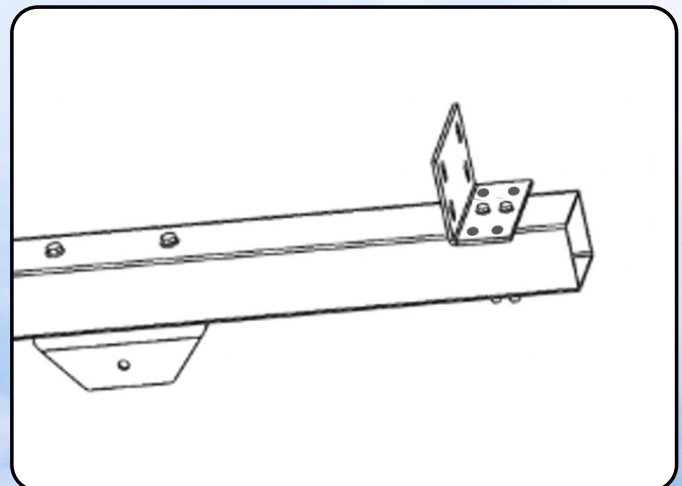
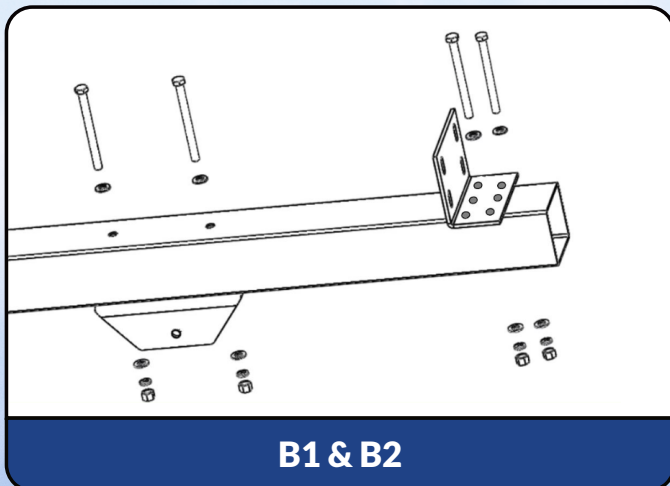
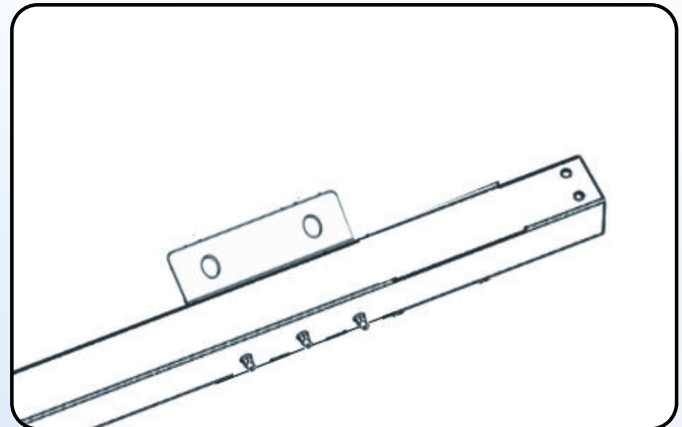
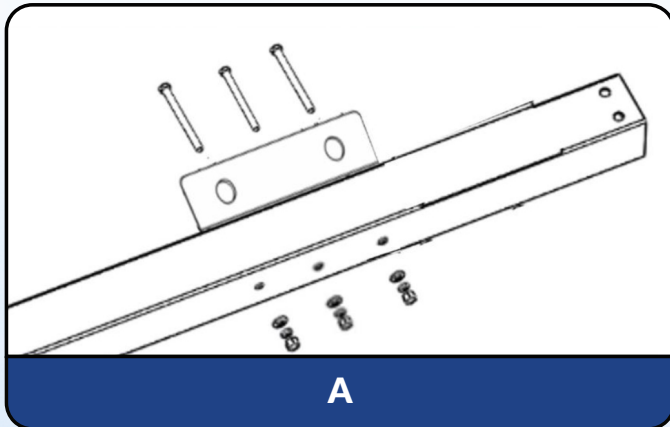

## Adapter Placement Diagram

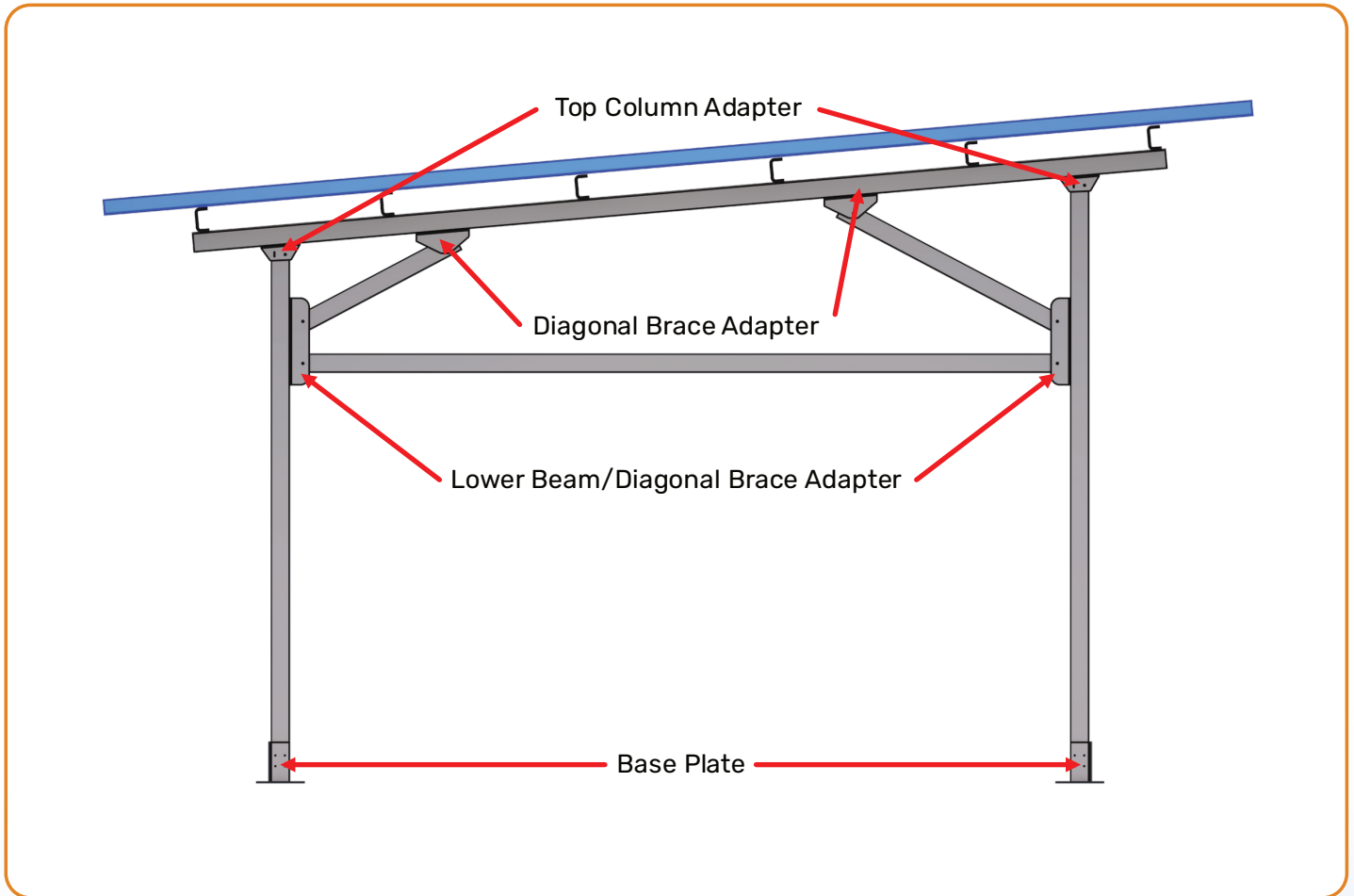

Please Note: The Top Column adapter has an oval and a round shaped hole. The oval should be facing closest to the low side of the structure on both the front and rear column.

## 4. Connect Columns

- ✓ Attach Columns to base plate

Products Name	Quantity
Front Columns --- 111"	2
Rear Columns --- 126 ½"	2
M16*180mm Bolt Kits (1 flat washer + 1 spring washer + 1 nut)	16

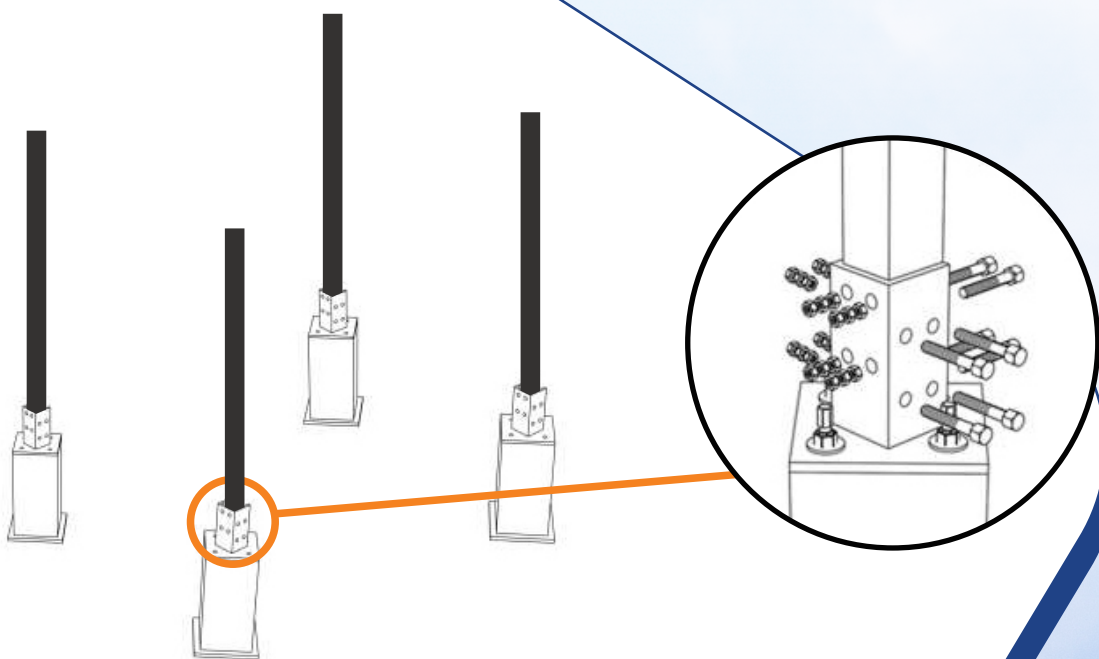

## 5. Connect Beams

- ✓ Connect Lower Horizontal Beam to front and rear Columns
- ✓ Connect Support Beam between front and rear columns on top
- ✓ Connect Diagonal Brace between Support Beam and Column

Products Name	Quantity
Lower Horizontal Beam 168 <sup>1</sup> / <sub>16</sub> "	2
Support Beam 228 <sup>5</sup> / <sub>16</sub> "	2
Diagonal Brace 47 <sup>3</sup> / <sub>16</sub> "	4

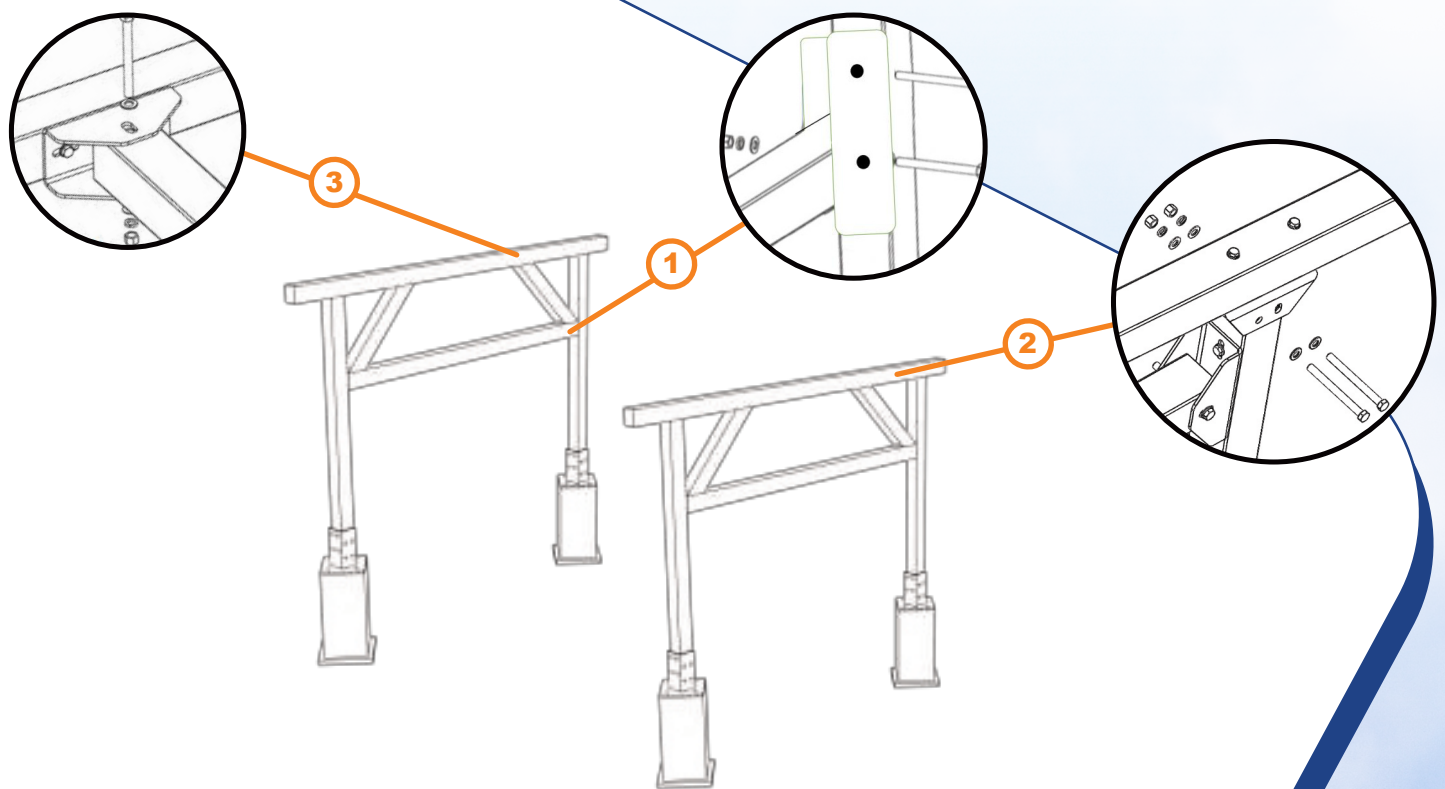

## 5. Connect Beams (Continued)

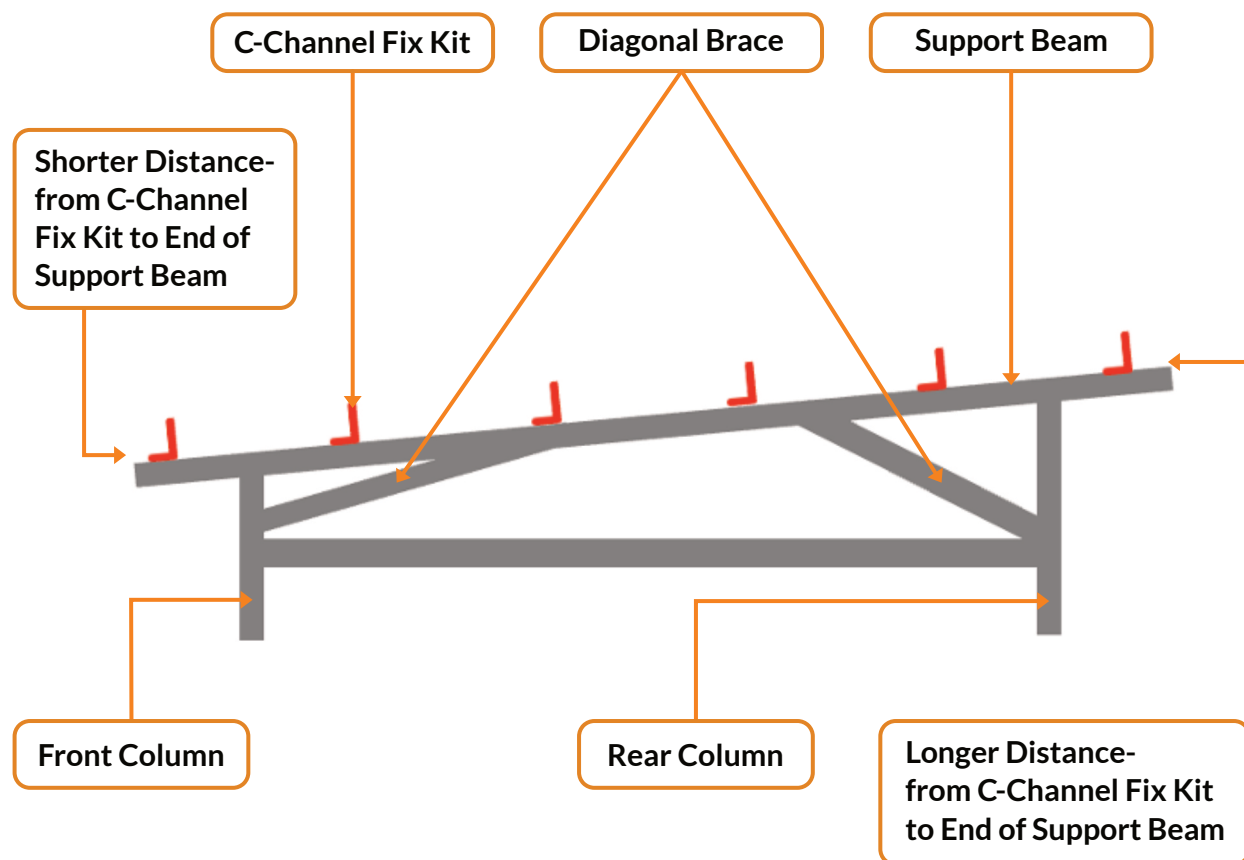

When connecting the Support Beam to the front and rear columns ensure the orientation matches the above image. The low side of the Support Beam will have a much shorter distance from the C-Channel Fix kit to the end of the Support Beam whereas the high side will have a greater distance from the end of the Support Beam to the C-Channel Fix Kit.

## 6. Fix C-Channel

- ✓ Use C-Channel Fix Kit to connect C-Channels to Support Beam
- ✓ Use M10\*16mm Bolt Kits (1 flat washer + 1 Spring Washer + 1 Nut)
- ✓ Use M10\*25mm Bolt Kits (1 flat washer + 1 Spring Washer + 1 Nut)

Products Name	Quantity
C Channel 149 <sup>5</sup> / <sub>8</sub> "	6
C-Channel Fix Kit	12
M10*40mm Bolt Kits (1 flat washer + 1 spring washer + 1 nut)	48
M16*180mm Bolt Kits (1 flat washer + 1 spring washer + 1 nut)	24

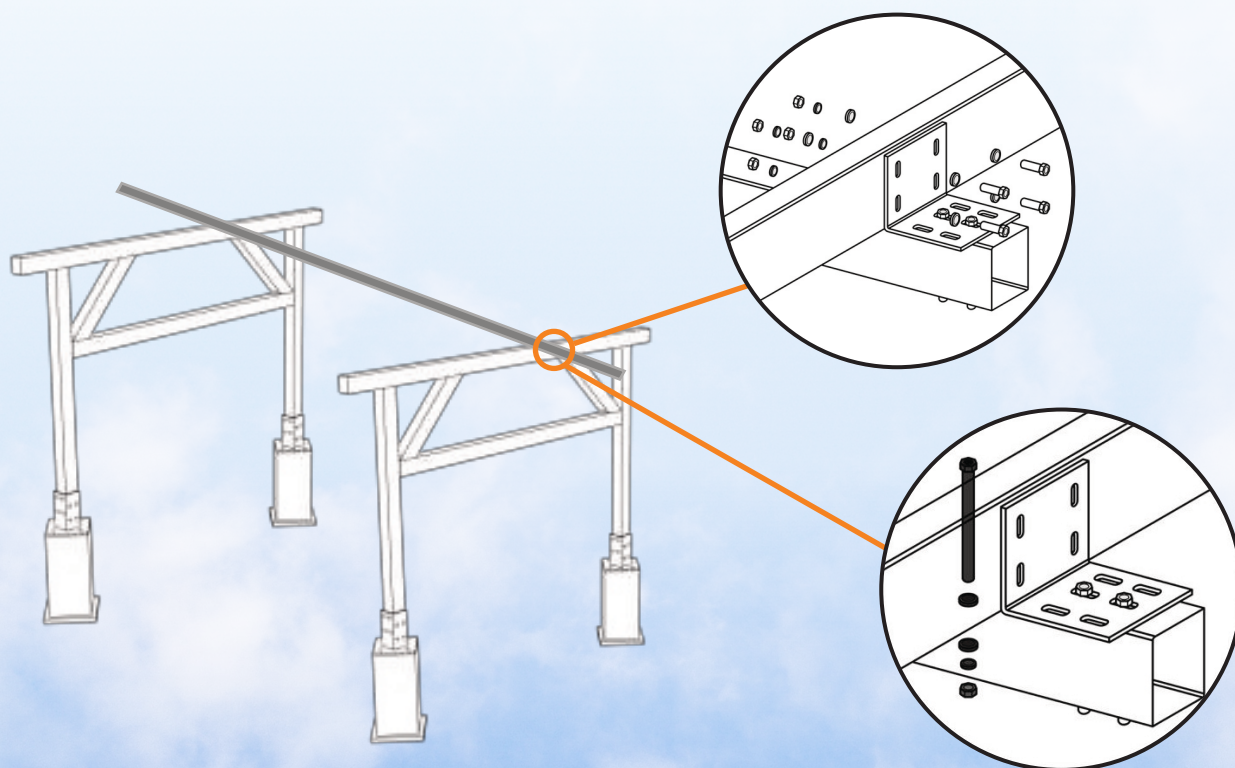

## 7. Connect M-Rails and Pre-assemble clamps on M-Rail

Determine overall M-Rail length by calculating the total M-Rail length needed, this length will correspond with the overall module length and any additional length desired. (The M-Rail can remain flush from top to bottom with the exterior panel frames or it can be extended slightly on the low side of carport for extended water diversion.)

Mechanically connect the 2 M-Rail sections with 2 M6\*16 on the exterior walls of the M-Rail. Do not connect in the valley of the M-Rail. Apply waterproof adhesive at seam where 2qty M-rails overlap after they have been mechanically attached.

- ✓ Connect M-Rails to desired length
- ✓ Pre-fix share plate on M-Rail
- ✓ Re-check measurements for Mid Clamps or End Clamps
- ✓ Attach each Share Plate with 2qty M6\*16

TIP: Place 2-Mrails in parallel on a flat level surface, then lay 3 or 4 modules on top of the M-Rails, ensuring proper spacing, then mark your share plate locations. Use these location measurements to install the remaining share plate locations on the remaining M-Rails. (3 or 4 module option correlates with your overall array configuration).

Products Name	Quantity
M Rails – 142 1/8”	8
Share Plates	32
Mid Clamps	16
End Clamps	16
M6.3*16	64

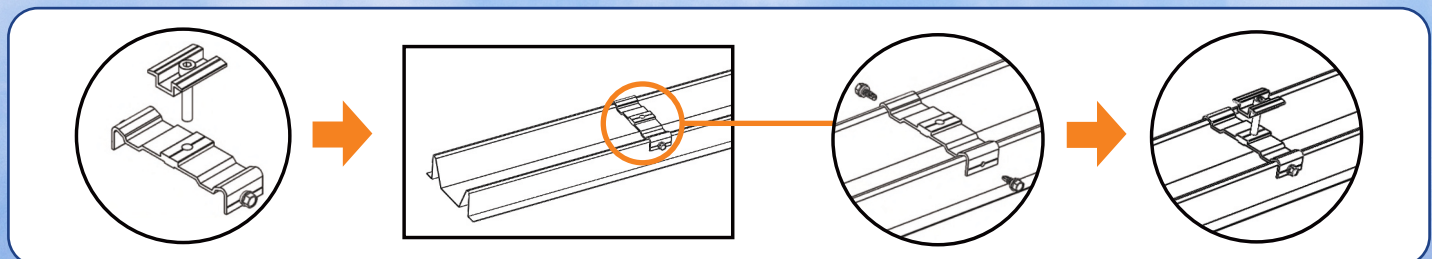
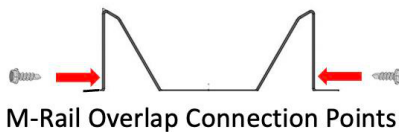

## 8. Fix M Rail

- ✓ Use M6.3 self tapping screw to fix M-Rail to C-Channel
- ✓ M-Rails with End Clamps will be located on the exterior rows
- ✓ M-Rails with Mid Clamps will be located on the interior rows
- ✓ After installing the first two rows of M-Rails, install one column of modules to ensure distance, seating, and placement of Modules are correct.
- ✓ After first two rows of M-Rails have been installed and all distances and measurements have been confirmed as accurate proceed with installation of remaining M-Rails.

TIP: If possible lay 4qty M-Rails down on flat level surface; place 3 panels across these M-Rails in Portrait configuration, ensure rails and panels are square; take measurement to confirm your starting M-Rail attachment location.

Please Review Math Calculation in Appendix

Products Name	Quantity
M Rails 142 1/8"	8
M6.3*16	36

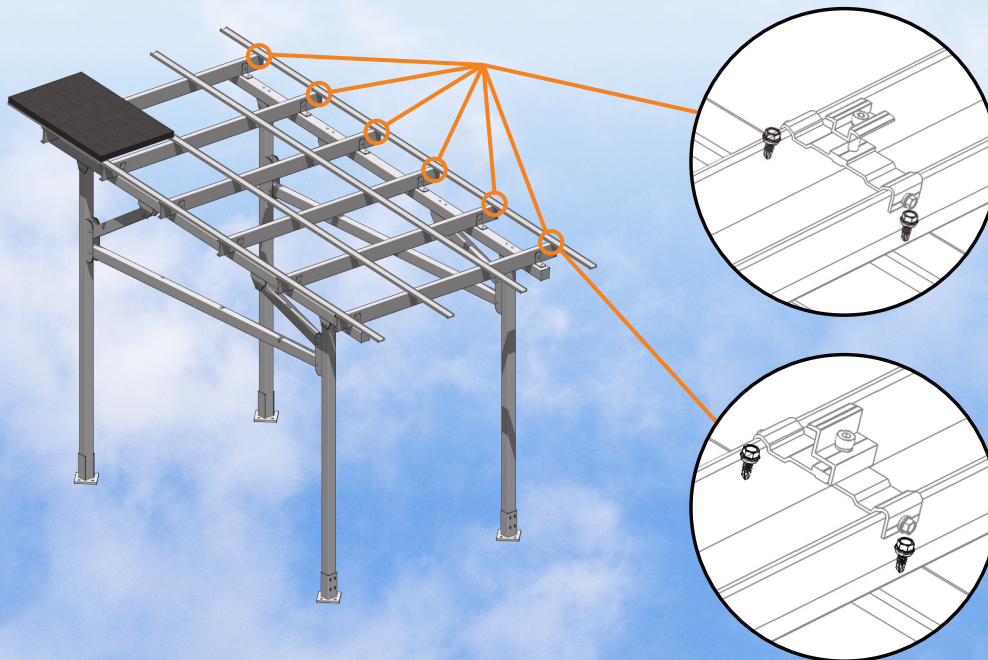

## 9. Install L-Angle Supports

L-Angle supports provide continuous stability and reduce any twisting or settling that may occur within the C-channel system. The L-Angle supports are attached to the bottom-center of the C-Channels using M8 screws. Each L-angle support will be attached with 6-qty M8 screws at 6 separate contact points on six separate C channels. The L-Angle support will run Perpendicular to the C-Channels and parallel to the Top Support Beam. The L-Angle supports will be installed in the center of each car bay (See Diagram Below).

Products Name	Quantity
L-Angle Support 224 <sup>7</sup> / <sub>16</sub> "	1
M8 Screws	6

### L-Angle Support Installation Locations

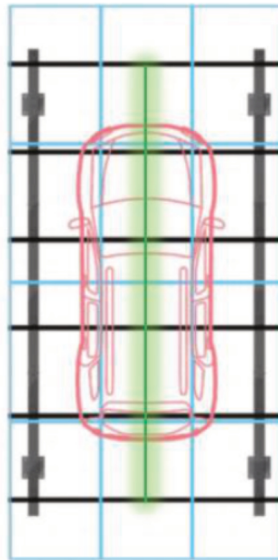

 = L-Angle Support

## 10. Install Solar Panels

- ✓ Install Rubber Stripping to the exterior of module frame but only where the frames are adjacent to other module frames on all interior seams. These interior seams will all be on the short side of the module running in a horizontal direction.
- ✓ Install water channel where 2 panels meet under the module frame

Products Name	Quantity
Modules	9 or 12
Rubber Stripping	1 Roll
Water channel	9

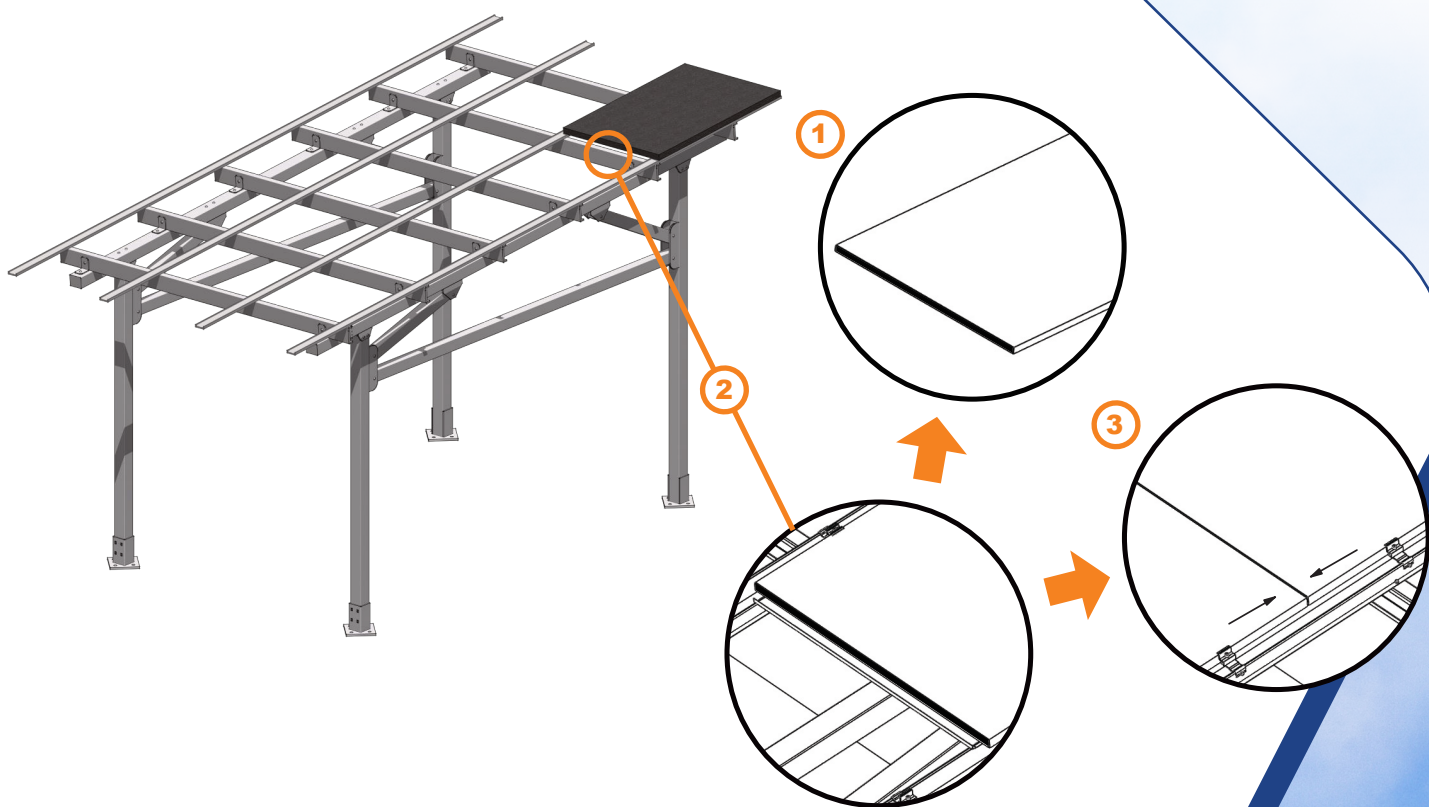

## 11. Grounding- Lug and Wiring

Install grounding lug at end of C-Channel on side of array that is most optimal for wire management. Ensure that all paint and any debris is removed from bonding site to achieve proper bonding connection. Attach each ground lug with a stainless steel nut then cross 8.4mm<sup>2</sup> or greater than or equal to 8AWG copper wire through all 6 grounding lugs (fixed by M8\*20 inner hex bolt), run the copper ground wire along the column, and down into the ground attaching to an approved ground rod or other acceptable ground. The grounding lug completes a grounding function when fastened tight to connect all 6 C-Channel and copper wire.

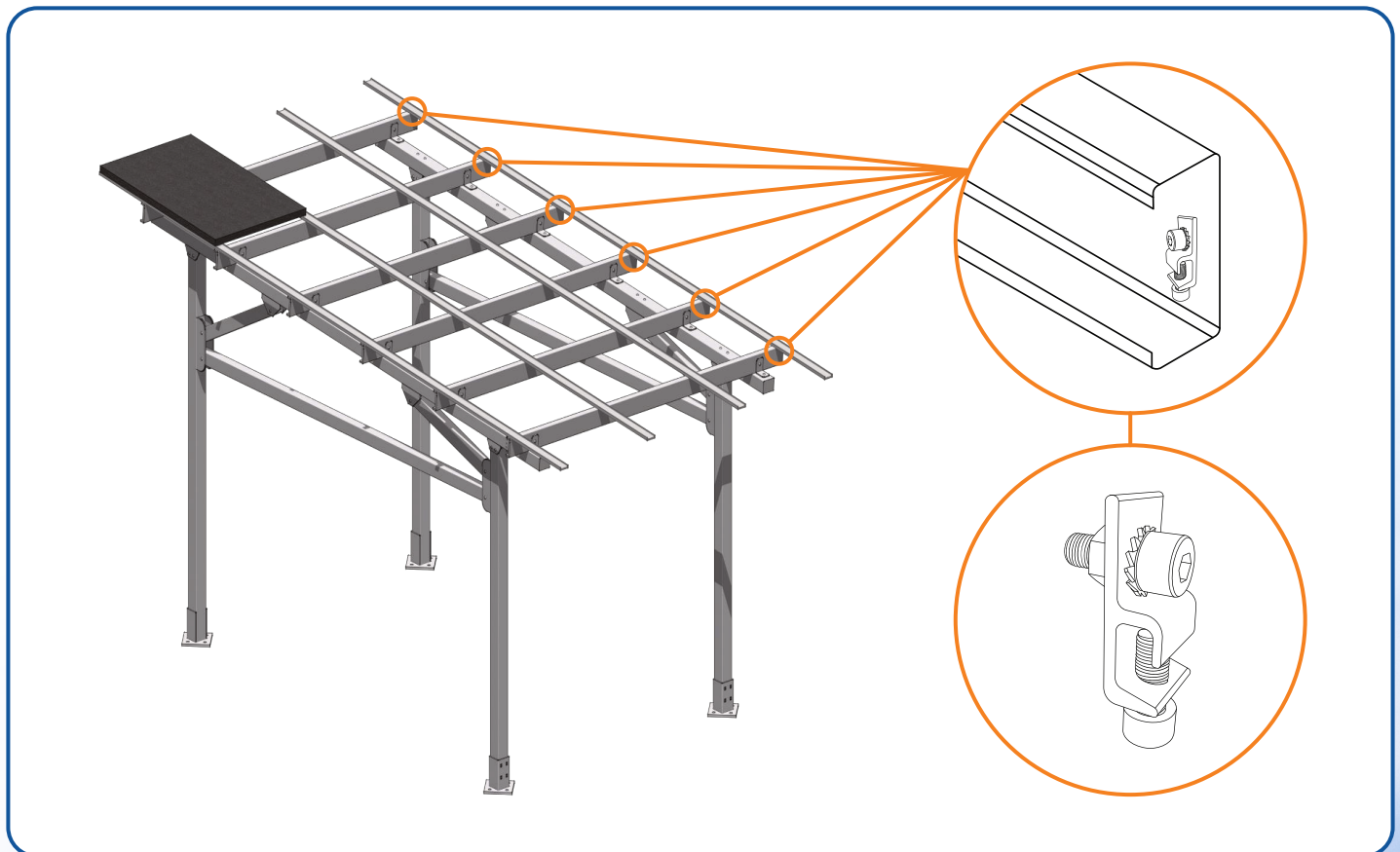

### Electrical Characteristics of AWG Copper Wire

AWG	Diameter [inches]	Diameter [mm]	Resistance [Ohm / 1000ft.]	Resistance [Ohm / km]	Max Current [Amperes]	Max Frequency for 100% skin depth
6	0.162	4.1148	0.3951	1.295928	37	1100 Hz
7	0.1443	3.66522	0.4982	1.634096	30	1300 Hz
8	0.1285	3.2639	0.6282	2.060496	24	1650 Hz
9	0.1144	2.90576	0.7921	2.598088	19	2050 Hz
10	0.1019	2.58826	0.9989	3.276392	15	2600 Hz

## 12. Grounding – Lug and Wiring Diagram

Installation herein is in accordance with the National Electrical Code, ANSI/NFPA70. Grounding LUGS are intended for use with one solid or stranded copper wire. Final conductor wire size to be determined by licensed electrician and/or designer relative to job size.

### Temporary Grounding and Bonding Procedure:

Periodic inspections should be conducted on the PV array to ensure There not any loose components, loose fasteners, or corrosion. If any of these items are found, the affected components are to be immediately replaced. If removing a module creates a discontinuity in the array which interrupts the Ground path, a temporary bonding jumper must be used to ground the isolated array and ensure safety of the personnel and PV system.

**NOTE:** Removing a PV module from a system is not considered routine maintenance. This type of activity should only be performed by trained and qualified installers.

**CAUTION:** Module removal may disrupt the bonding path and could introduce the risk of electric shock. Additional steps may be required to maintain the bonding path. Modules should only be removed by qualified persons in compliance with the instructions in this manual.

**NOTE:** In order to prevent corrosion induced by dissimilar metals, it is important to verify that the bare copper wire does not come into contact with aluminum; these materials must be kept separate the PV array to ensure There not any loose components, loose fasteners, or corrosion. If any of these items are found, the affected components are to be immediately replaced. If removing a module creates a discontinuity in the array which interrupts the Ground path, a temporary bonding jumper must be used to ground the isolated array and ensure safety of the personnel and PV system.

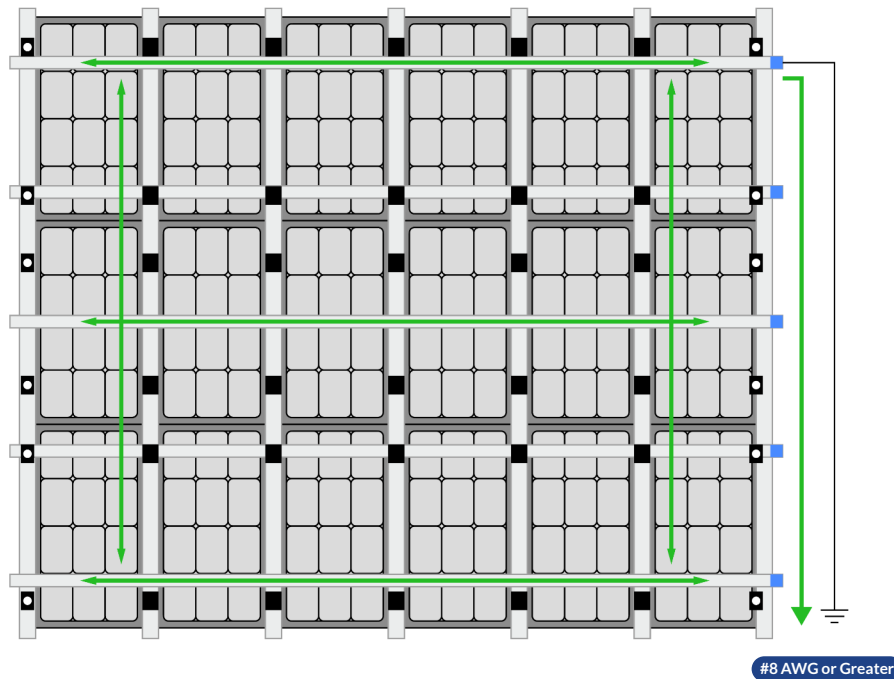

Grounded End Clamp
  Grounded Mid Clamp
  Ground Path
  Grounding Lug

## 13. Final Check

- ✓ Check and verify that all components are properly fastened and installed properly in their correct positions and locations.
- ✓ Verify and re-adjust all components as needed within the structure.

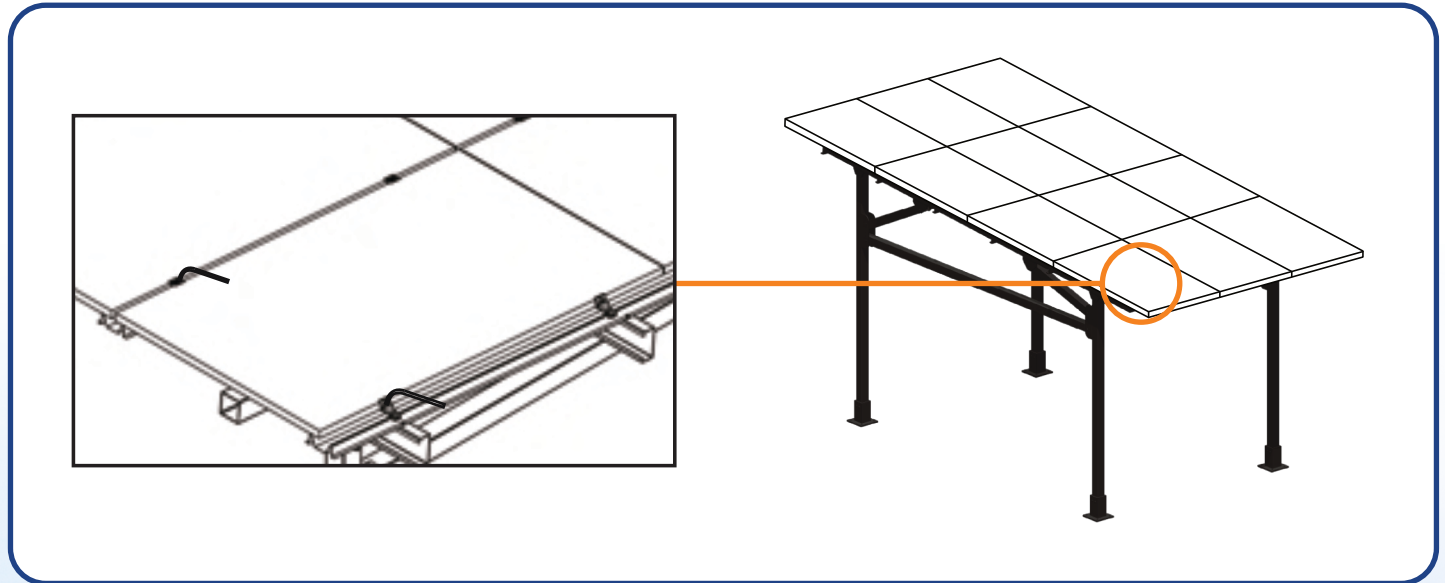

## 14. Hide Footing (Optional)

- ✓ Cladding of 4 bases is an option with engineer approval.

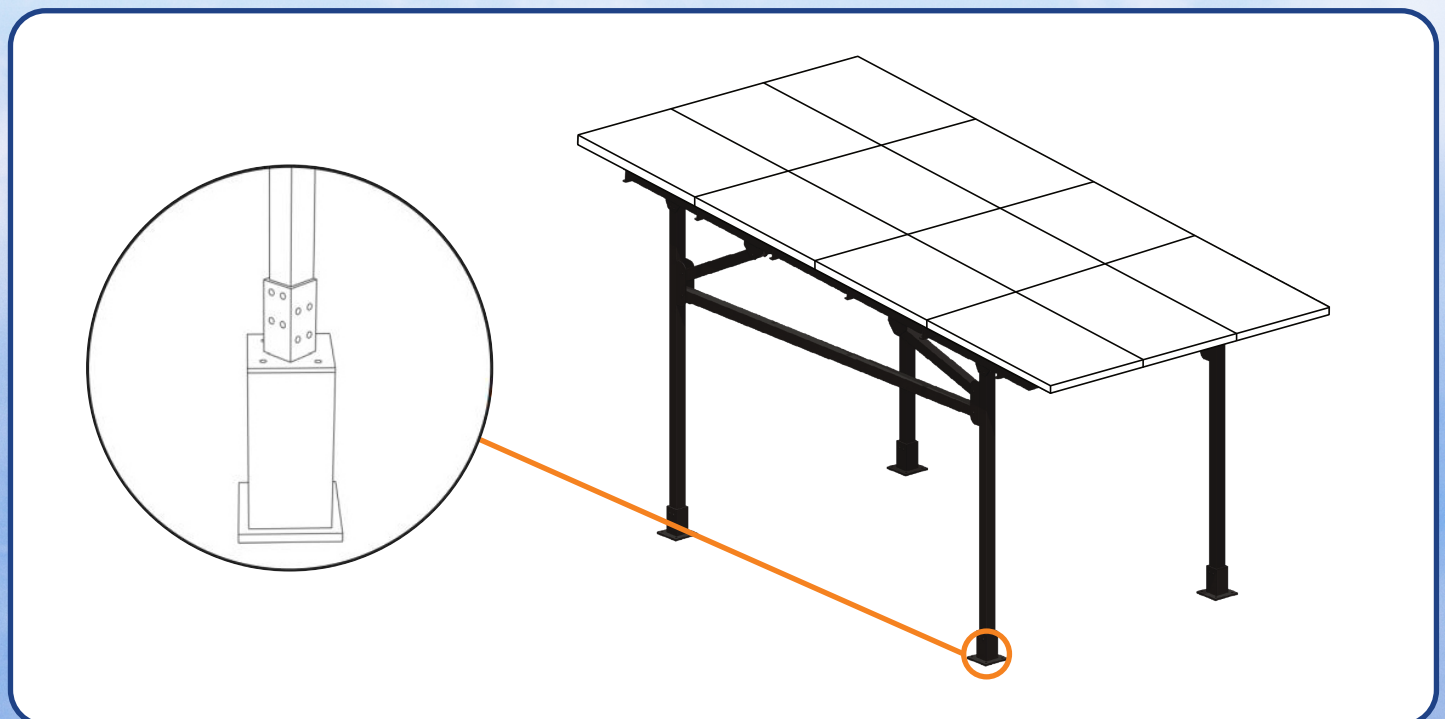

## TORQUE SPECIFICATION - CARPORT

	Grounding Lug	Fix M Rail to C Purlin Screw M6.3 X 25	Mid/End Clamp M8	C Rail Splice Kit M 10 * 30	Rail Fix Kit to Column M16	Rail Fix Kit to C Rail M10	Structure (incl Column Adapter, Base Plate M16
<b>Torque in N-m</b>	<b>6</b>	<b>12</b>	<b>16</b>	<b>28</b>	<b>30</b>	<b>34</b>	<b>40</b>

Note : The above values are expressed as N-m,- "Newton-meter"

	Grounding Lug	Fix M Rail to C Purlin Screw M6.3 X 25	Mid/End Clamp M8	C Rail Splice Kit M 10 * 30	Rail Fix Kit to Column M16	Rail Fix Kit to C Rail M10	Structure (incl Column Adapter, Base Plate M16
<b>Torque in ft/lb</b>	<b>4.5</b>	<b>9</b>	<b>12</b>	<b>21</b>	<b>22.5</b>	<b>22.5</b>	<b>30</b>

Note : The above values are expressed as "foot-pound"

# WORLDLEADING

---

## M A N U F A C T U R E

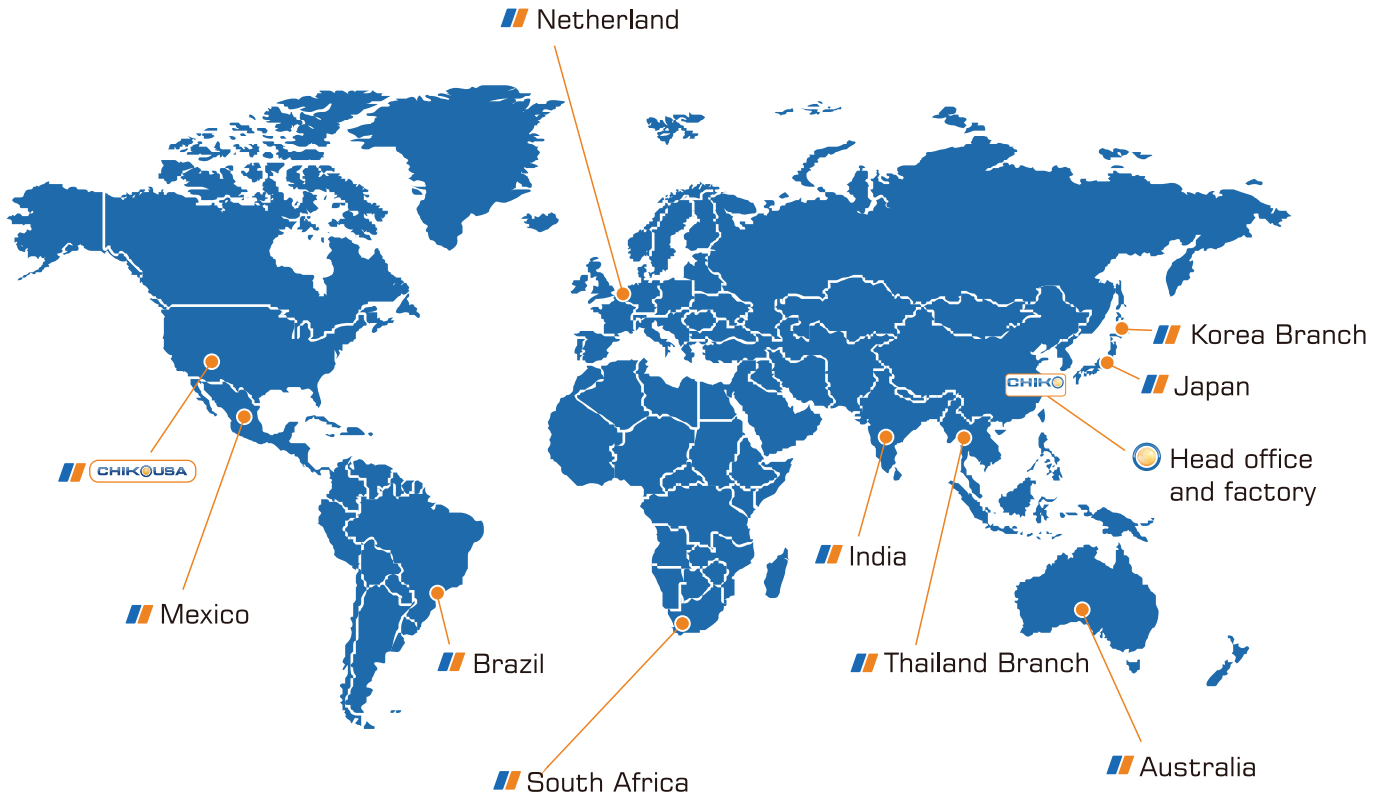

**CHIKOUSA**  
RACKING MADE SIMPLE

Tel : 1-800-948-5390

Email : [info@chikousa.com](mailto:info@chikousa.com)

[www.chikousa.com](http://www.chikousa.com)



16413 North 91st Street  
STE C-115  
Scottsdale, AZ 85260

# CHIKOUSA PREMIER ONE CAR CARPORT

**Panel Layout : 4x3**

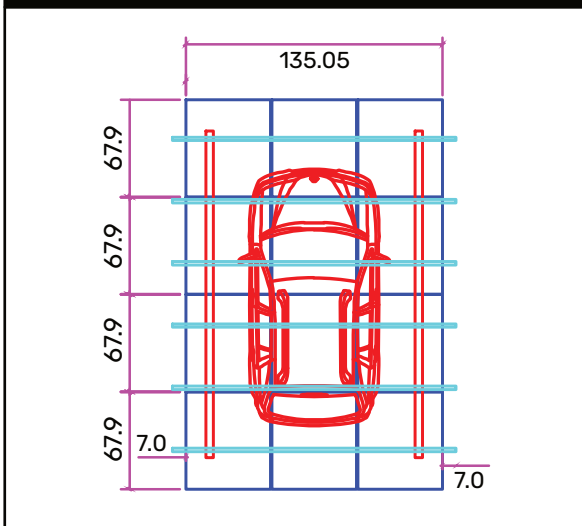

**C-Channel Layout**

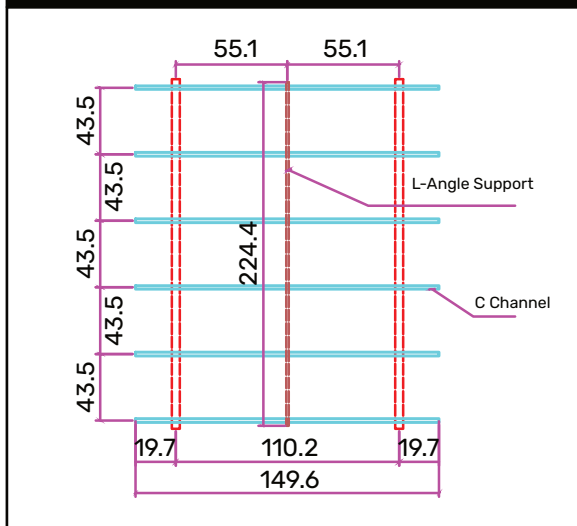

**Layout : 4x3**

**BOM**

NO	DESCRIPTION	QTY
1	Beam & Column Set	2
2	End Clamp	16
3	End Clamp share plate	16
4	Mid Clamp	16
5	Mid Clamp share plate	16
6	C-Channel Fix Kit	12
7	C-Channel 149.6	6
8	C-Channel Splice Kit	X
9	M Rail - 142.1	8
10	L-Angle Support 224.4	1
11	Water Channel	9
12	Rubber Stripping	9
13	M6. 3*16 (M Rail)	32
14	M6. 3*16 (End & Mid Clamp share plate)	64
15	M6. 3*25 (M Rail & C Channel)	48

**C Channel & M Rail Layout**

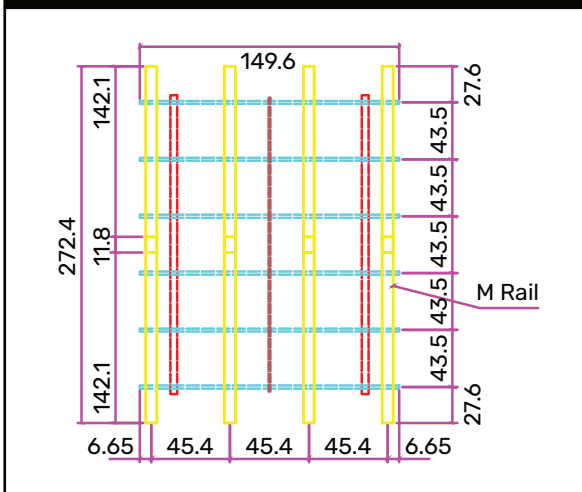

**Foundation Layout**

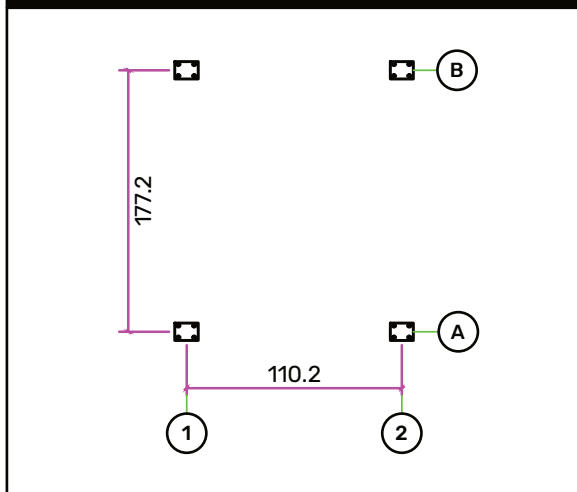

Design Factors :  
 Module Dimensions : 67.9 x 44.6  
 Tilt Angle : 5°  
 Front Clearance : 111  
 Wind Speed : --  
 Snow Load : --

Modify by	Doc No.	Data	Des	J. Burton	231130
			Drw		
			Check		
			Craft		
			App		

**CHIKOUSA**

**Beam & Column Set**

**4x3-5°**

View :

Rate

Page /

# CHIKOUSA PREMIER ONE CAR CARPORT FOUNDATION LAYOUT

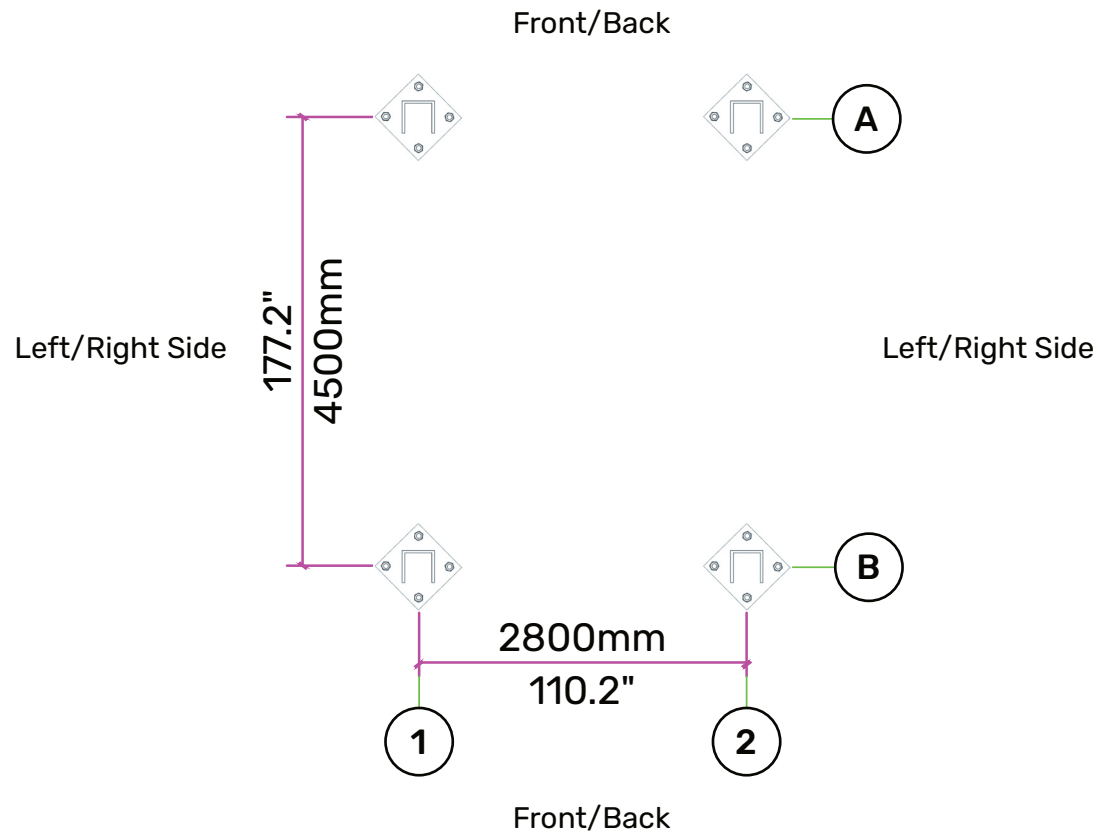

Note: Base Plates shown can rotate 180° based on aesthetic preference.  
The C opening can either face down (image shown) or up. The C-opening cannot face to either the left side or the right side.

	Modify by	Doc No.	Data	Des	J. Burton	230417	<b>CHIKOUSA</b>	
				Drw			Premier 1-Car	
				Check				
				Craft				
				App			View :	Rate
								Page /



# CHIKOUSA CARPORT BASE PLATE (VERSION 2.0)

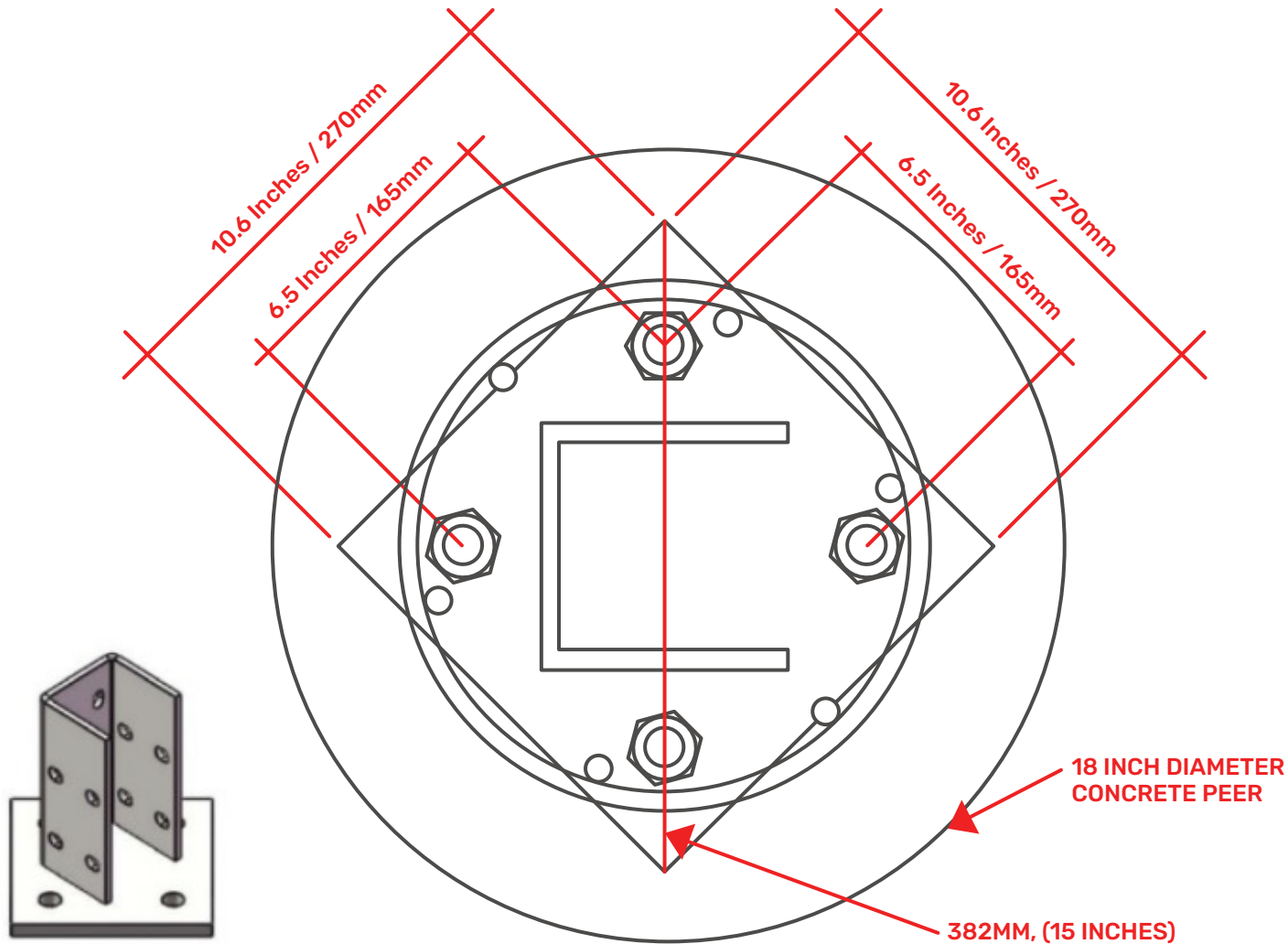

**HOLES IN BASE PLATE BOTTOM-M30/30MM (approx 1.2 Inches)  
BOLTS per engineering-THICKNESS-1 INCH or M27;  
LENGTH 24 INCHES APPROX (21" IN GROUND; PLUS ABOVE GROUND FOR NUTS)**

# CHIKOUSA FOUNDATION ILLUSTRATIONS FOR PIER FOOTINGS

## Concrete (if required):

- All concrete work shall conform to ACI standards and specifications
- 4,000 psi Compressive Strength min. ( $f_c$ ) at 28 days
- Type II Cement
- Maximum slump of 5'
- Concrete shall be air entrained in accordance with IBC Section 1904.2 and ACI 318
- Special Inspection is not required unless required by the Building Department/Official
- Aggregates shall be per ASTM C33 (Max. size 1-1/2")
- The mix design is to be adjusted for local soil and exposure conditions and shall be approved by the Engineer of Record

## Reinforcing Steel (if required)

- Shall be per ASTM A615 Grade 60 (deformed)
- Min  $F_y$  = 60 ksi for #4 bars and up;  $F_y$  = 40 ksi for #3 bars
- Shall be free of rust and dirt
- Rebar splices shall have a lap no less than 48 bar diameters unless noted otherwise
- All clear cover distances shall be 3" unless noted otherwise.

Engineering has concluded that using (4)qty 1" diameter anchor bolts with a 21" effective embedment is acceptable.

**All bolts shall be installed within the pier/pedestal circular rebar cage.**

## Cylindrical Concrete Pier Footing Details

18" Diameter Cylindrical Concrete Pier footing  
Rebar is required to be (6) #5 Longitudinal Bars with #3 Ties @ 6" O.C. for the entire pier depth.

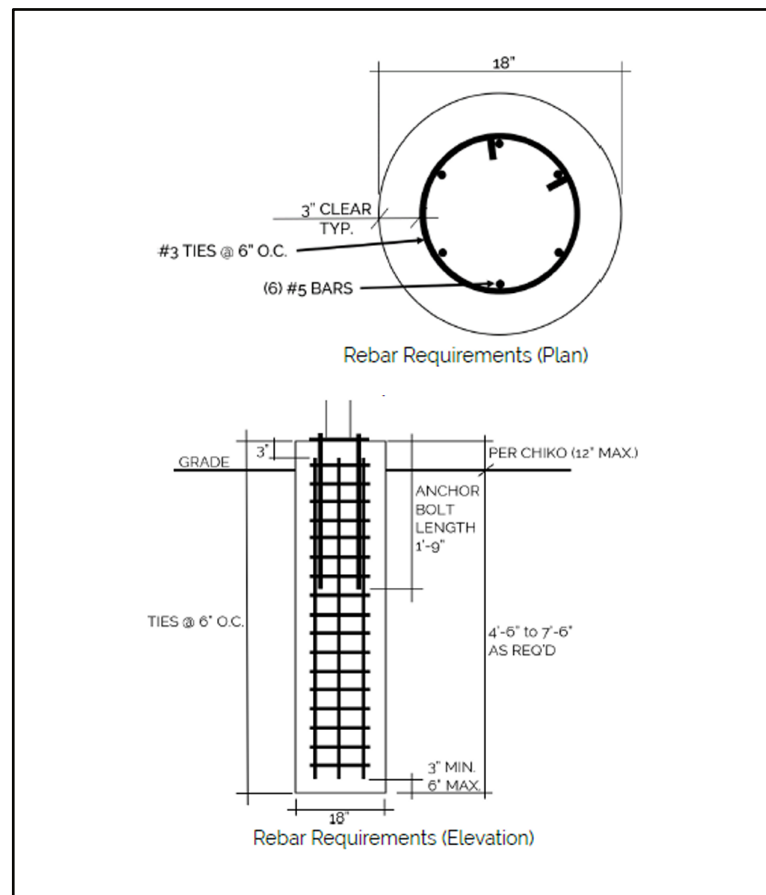

**Note: For exact concrete depth, see charts in engineering report.**



# WHERE TO GET FOUNDATION BOLTS?

<https://www.anchorboltexpress.com/1x24-w-6-thread-f1554-grade-55-galvanized-straight-anchor-bolt/>

## 1" X 24" W/6" THREAD F1554 GRADE 55 GALVANIZED STRAIGHT ANCHOR BOLT



(1 Review)  
Write a Review

**SKU:** AS100024G  
**WEIGHT:** 5.83 LBS  
**SHIPPING:** Calculated at Checkout

### BULK DISCOUNT RATES

Below are the available bulk discount rates for each individual item when you purchase a certain amount.

Buy 11 - 25	and get \$0.26 off
Buy 26 - 50	and get \$0.52 off
Buy 51 - 100	and get \$0.78 off
Buy 101 above	and get \$1.44 off

# \$22.30

### WELDED NUT

Check to add tack welded nut on the bottom threads.

**QUANTITY**

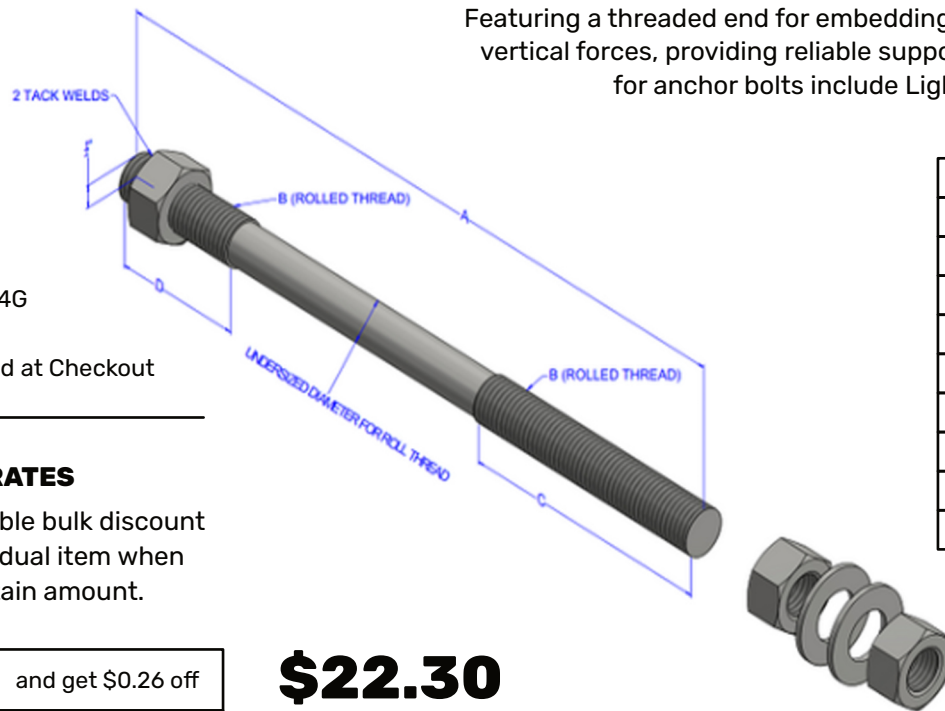

## 1"x24" Structural Anchor Bolt, and minimum 6" Thread Length.

Straight anchor bolts, meeting with ASTM standard F1554, are essential for securing structural supports like building columns and street lighting to concrete foundations. Featuring a threaded end for embedding into concrete, they ensure stability against lateral and vertical forces, providing reliable support for various applications. Some common applications for anchor bolts include Light Poles, Steel Building Columns, and Machinery Bases.

Material	F1554 Grade 55-S1 Galvanized
Diameter (Min.) A	0.9100"
Length B	24"
Thread Size	1" - 8
Thread Length C	6" Min,
Thread Length D	2" Min,
Anchor Type	Straight (I)
Thread	Right Hand, UNC Course Thread Class 1A
Included Hardware	2 Hvy. Nuts, 2 Flatwashers
Country of Origin	Bolts: United States, Hardware: Non-Domestic

\*Anchor Bolts are roll threaded per the F1554 Standard, bolt body will be undersized per the standard (Min, of 9100")

DIAMETER (A)	1"
OVERALL LENGTH (B)	24"
TOP THREAD LENGTH (C)	6" Minimum
BOTTOM THREAD LENGTH (D)	2" Minimum
MATERIAL	F1554 Grade 55-S1
FINISH	Hot Dip Galvanized
THREADS	1" - 8 UNC
COUNTRY OF ORIGIN	Bolts: United States, Hardware: Non-Domestic

# CHIKOUSA PREMIER CARPORT SIDE PROFILE AND PARTS DIAGRAMS

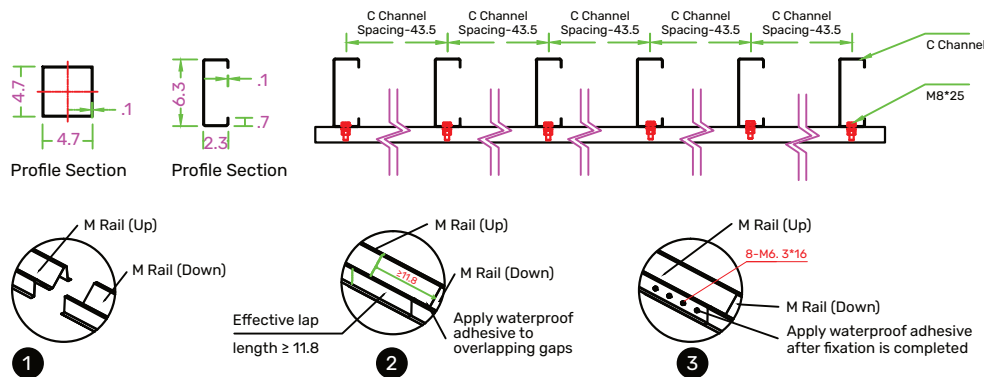
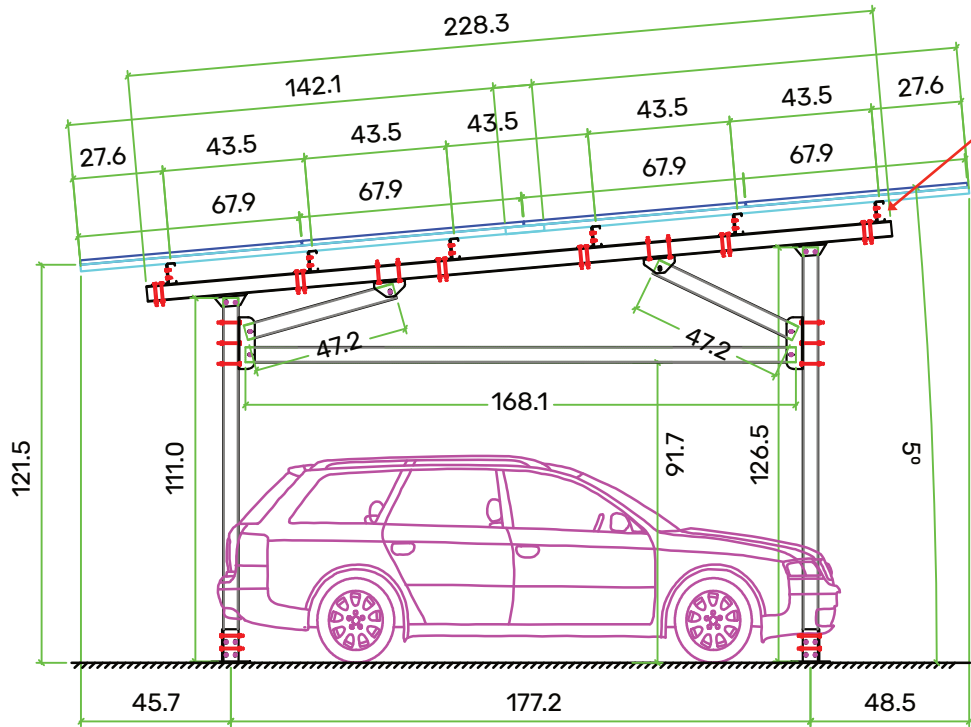

(Please note: the open side of the C-Channel faces the high side of the Carport)

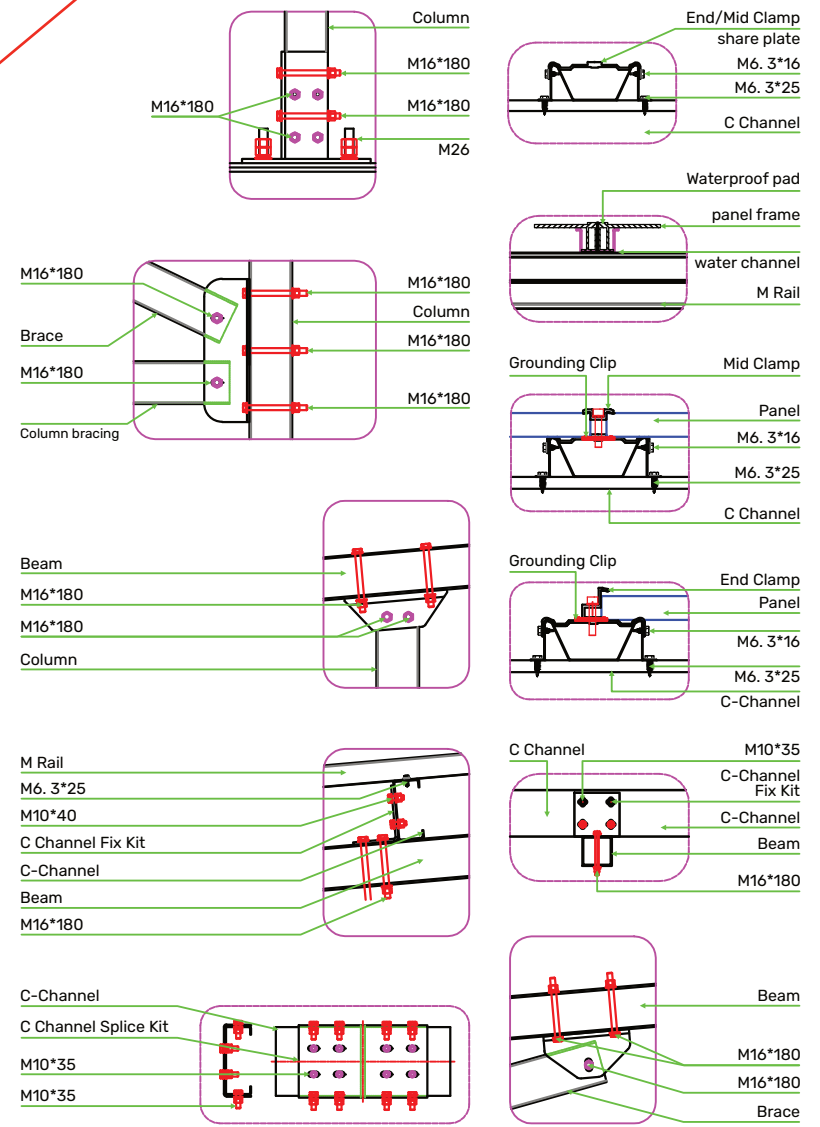

Design Factors	:	
Module Dimensions	:	67.9 x 44.6
Tilt Angle	:	5°
Front Clearance	:	111
Wind Speed	:	
Snow Load	:	--

Modify by	Doc No.	Data	Des	J. Burton	231130
			Drw		
			Check		
			Craft		
			App		

**CHIKOUSA**

**Support Rack**

**4xa-5°**

View :

Rate

Page /

# CHIKOUSA PREMIER CARPORT CONNECTIONS

