

DATA SHEET

The CHIKOUSA Monster Mount utilizes ground breaking piling technology. The Monster Mount has been specifically designed to eliminate concrete foundations when installing either the CHIKOUSA Premier Solar Carport/Gazebo or the Maximo 185 Carport/Gazebo. Please note that a site-specific plan approval is required for usage with the Maximo 185 version. The Monster Mounts unique, patented, geometric configuration and design is the most advanced ground attachment within the solar market today. The Monster Mounts unique configuration makes it a superior choice to conventional footer systems. The Monster Mount comes with 12 perimeter cylinder pile mounting options requiring 4 piles (4' Length). Once installed the Monster Mounts 4 piles lock into the ground resulting in an unmatched bearing capacity and pull-out resistance. The biggest advantages of the Monster Mount are cost savings, install time savings, and ease of installation.

MONSTER MOUNT

Install Site : Soil
 Material : Q235 Steel
 Dimension : 19" x 19"
 Treatment : Hot-Dip Galvanized
 Use : Foundation
 Part# : CK-GT-001-019-880
 Quantity : 1
 Weight : 53lbs

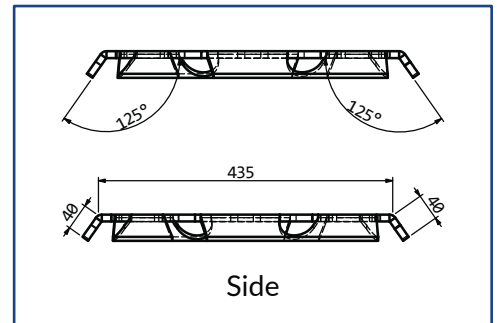
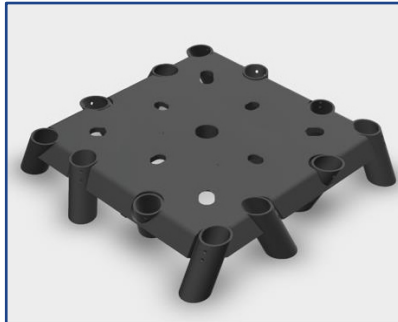

STEEL PILE

Material : Steel Q235B
 Dimension : 47" x 1.5"
 Treatment : Hot Dip Galvanized
 Use : Foundation
 Part# : CK-402-T1200
 Quantity : 4
 Weight : 20lbs

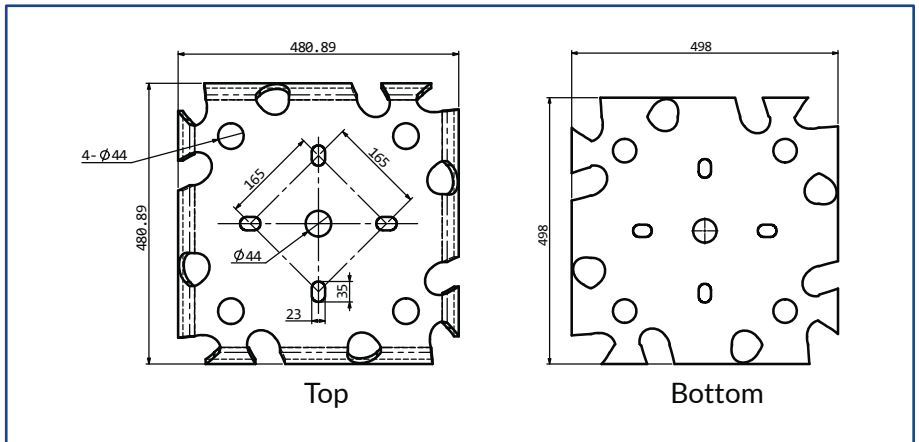

HARDWARE

5/16" X 1" or 8mm X 25mm Screw
 Quantity : 8
 Use : Parts Attachment
 Part# : CK-JST410-0800
 Type : Hardened Carbon Steel (Fu = 120ksi)

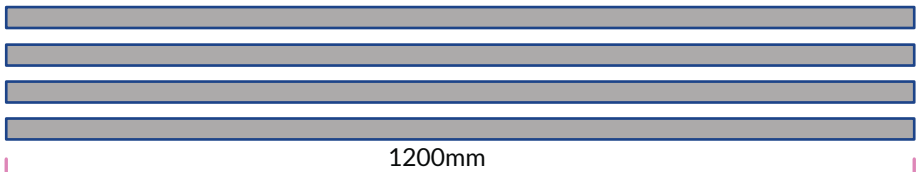

The Monster Mount is a complete system where the unique shape and high strength steel combines to create a very effective foundation. Once the piles are driven in and the base plate is secured, the opposing forces of multi-directional piles provide a solid and stable footing. The Monster Mount was designed to increase efficiency when resisting gravity, uplift, shear, and moment loads. This system ensures that the surrounding soil absorbs the majority of the applied stress.

The Monster Mount has proven to be an easy and cost-effective solution. This system can be utilized in a wide variety of soil types. The Monster Mount is fast and easy to install in most climates and geographic locations. Site disturbance is minimal, and the mounts are removable, reusable, and recyclable.

Environmental Advantage: Minimal environmental impact (small footprint).
 Materials are non-polluting to the install site and environment.